

June 2022



Leading the
**Responsible
Manufacturing**
Revolution



Why does Additive Manufacturing make a difference?

Responsible
Design

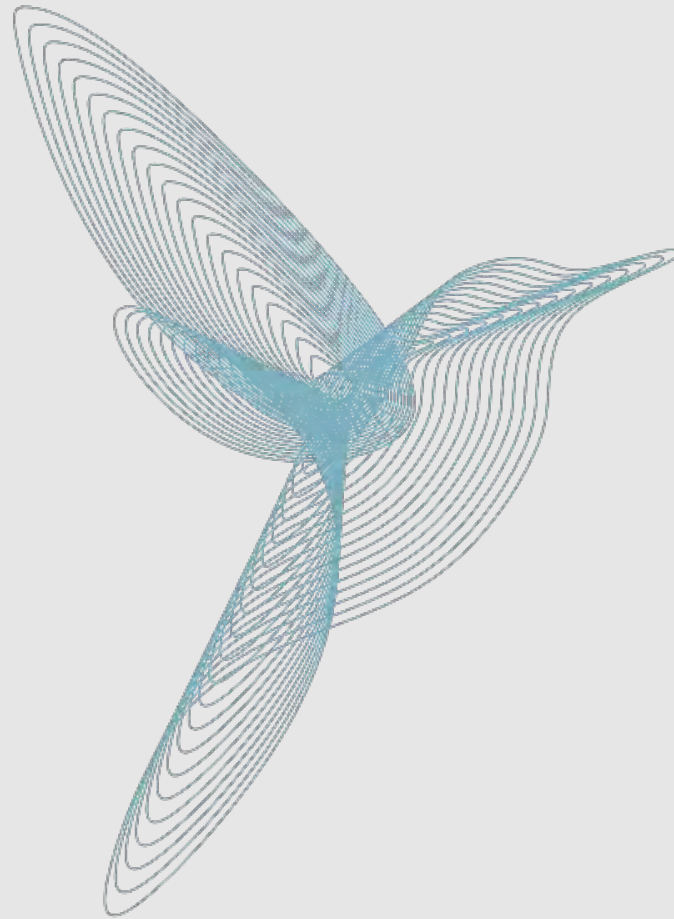

Responsible
and digital
Value Chain

Responsible Materials

Responsible Design: Example Airbus A350



Latch shaft – from 10 to 1 part

16 latch shafts per A350,
production cost: -25%

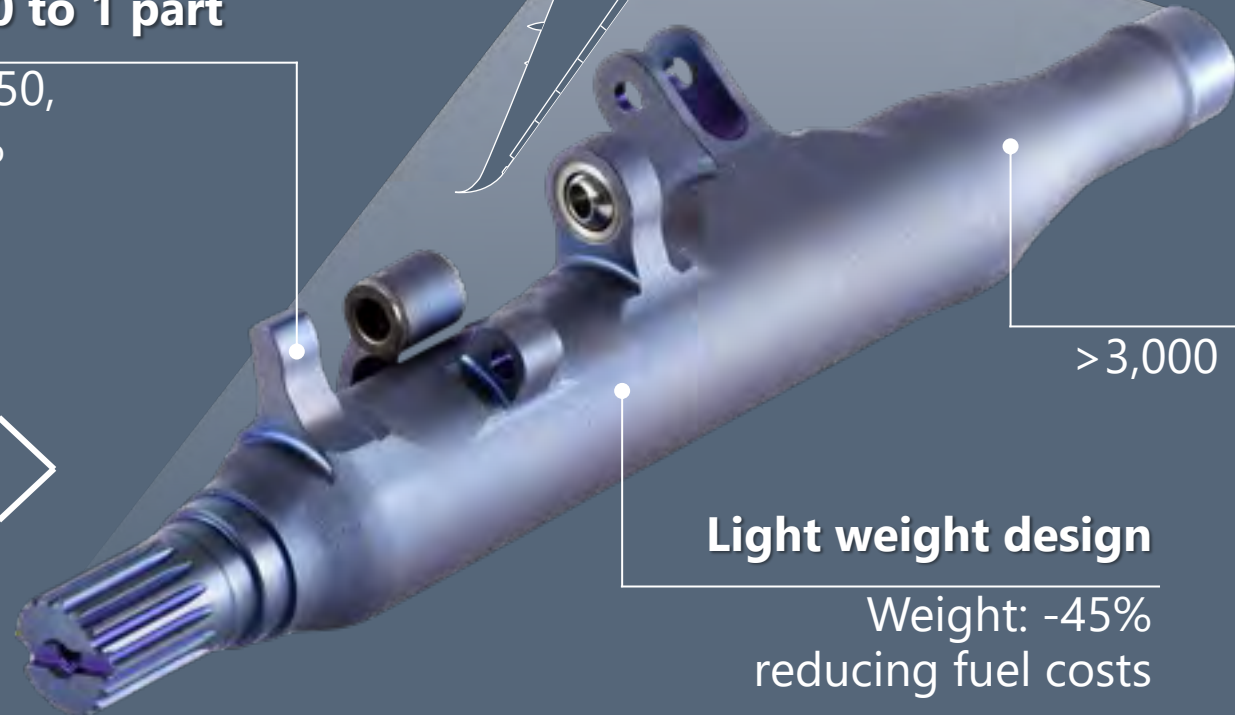
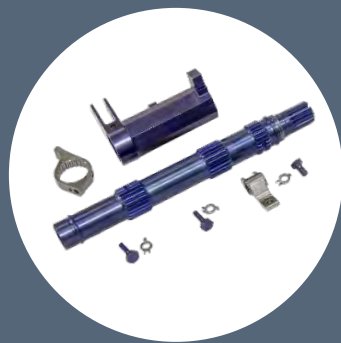

CO₂ reduction

>3,000 kg CO₂ per plane p/a

Light weight design

Weight: -45%
reducing fuel costs

Why does Additive Manufacturing make a difference?

Responsible
Design

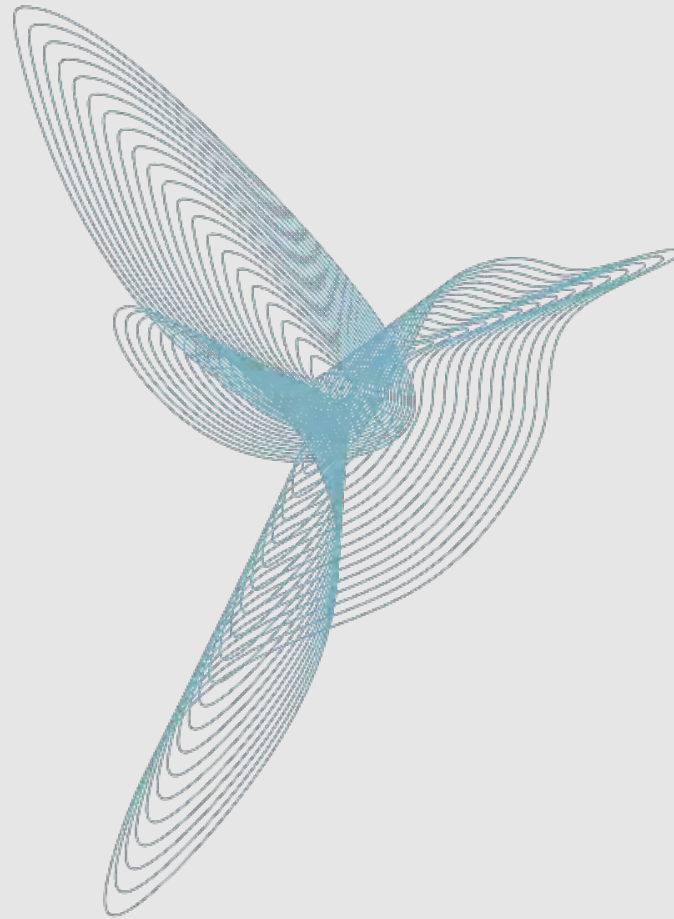

Responsible
and digital
Value Chain

Responsible Materials

Responsible Value Chain: Example printed eyewear

Customization

Custom 3D printed eyewear based on 3D scan



Local value chain
Production close to point of sale

Carbon emissions
[kg CO₂eq] *

-58%

Standard glass frame

Printed glass frame

* CO₂eq value comparison: conventional vs. YMW online customized eyewear

Picture source: YOU MAWO; Data source: „Comparison of the environmental impact of additively and conventionally manufactured eyewear frames (2021)“, not yet published

Why does Additive Manufacturing make a difference?

Responsible
Design

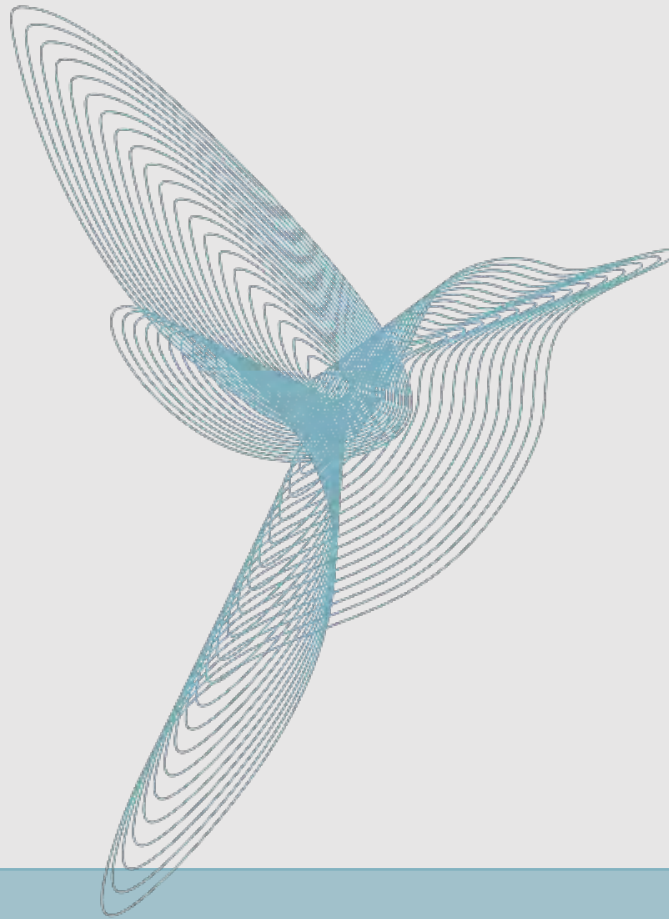

Responsible
and digital
Value Chain

Responsible Materials

Responsible Materials: Example carbon neutral PA 11

First ever carbon neutral AM powder

Two Nylon 11 materials carbon neutral certified
(from raw material to delivery in Europe and US)



Partnership

Joint development project with Arkema
(bio-based PA11 from renewable castor beans, Pragati in India)

External audit

LCA and carbon neutrality according to international standards
(ISO, PAS 2060, certified by TÜV)

Responsible Materials: Way forward

Optimized powder production

Improved production efficiency, local footprint, recycled materials



Additional base polymers

Polyamides (PA), Polypropylene (PP), Polylactide (PLA)

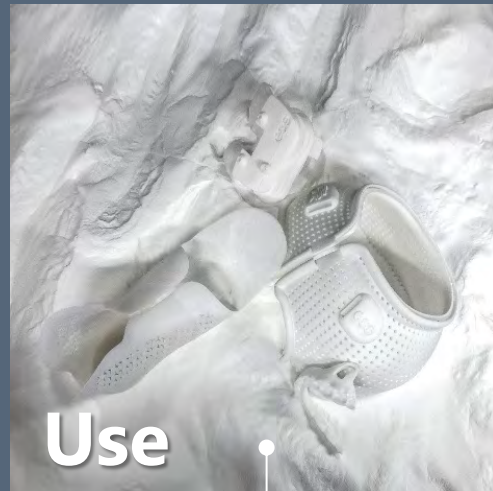

Optimized refresh

Sustainability optimized parameters (lower refresh rates), pure used powders, low refresh materials

Closing the material loop

AM part and powder recycling to granules, powder recycling to monomers

Thank you.



Questions? Nikolai.Zaepernick@eos.info